

# THE ANCESTRY OF TIBETAN

GEORGE VAN DRIEM  
UNIVERSITY OF BERN

## ABSTRACT (GEORGE VAN DRIEM)

The Tibeto-Burman linguistic phylum was identified in 1823. However, the term “Tibeto-Burman” was later used with two different meanings, one by scholars following Klaproth’s polyphyletic framework and another by scholars operating within the Indo-Chinese paradigm. Yet the enduring failure of Sino-Tibetanists to produce any evidence for the Indo-Chinese phylogenetic model compels us to conclude that there is no such language family as Sino-Tibetan. Instead, Tibetan forms part of the Trans-Himalayan linguistic phylum, or Tibeto-Burman in Klaproth’s sense. Robert Shafer coined the terms “Bodic” and “Bodish” for subgroups including Tibetan and languages with varying degrees of linguistic propinquity to Tibetan, and Nicolas Tournadre has also recently coined the term “Tibetic.” What are Tibetic, Bodish, and Bodic? Which languages are the closest relatives of Tibetan? What do we know about the structure of the Trans-Himalayan linguistic phylum as a whole? Based on the phylogeny of the language family, which inferences can be made about the ethnolinguistic prehistory of the Tibetan Plateau and surrounding regions?

## ALONG BOTH FLANKS OF THE HIMALAYAS

An account of the ancestry of Tibetan consists of two interwoven but distinct and, in principle, independent narratives, a historical account of the linguistic phylogeny of the language families of eastern Eurasia alongside a reconstruction of the ethnolinguistic prehistory of eastern Eurasia based on linguistic and human population genetic phylogeography. The first story traces the history of scholarly thinking regarding language relationships in eastern Eurasia from Tibeto-Burman to Trans-Himalayan. The path is strewn with defunct family trees such as Indo-Chinese, Sino-Tibetan, Sino-Himalayan, and Sino-Kiranti. In the heyday of racism in

scholarship, Social Darwinism colored both language typology and the phylogenetic models of language relationship in eastern Eurasia. Its influential role in the perpetuation of the Indo-Chinese model is generally left untold. The second narrative presents a conjectural reconstruction of the ethnolinguistic prehistory of eastern Eurasia based on possible correlations between genes and language communities. In so doing, biological ancestry and linguistic affinity are meticulously distinguished, a distinction that the language typologists of yore sought to blur, although the independence of language and race was stressed time and again by prominent historical linguists.

#### FROM TIBETO-BURMAN TO TRANS-HIMALAYAN

The Tibeto-Burman linguistic phylum was identified in 1823. However, the term “Tibeto-Burman” was subsequently used with two different meanings, one by scholars following Julius von Klaproth’s polyphyletic framework and another by scholars operating within the Indo-Chinese or Sino-Tibetan paradigm. The essential differences between the two lineages of thought are contrasted, and the evidence is weighed. The geographical distribution of major subgroups and the phylogeny of the language family provide clues to Tibeto-Burman ethnolinguistic population prehistory. Several alternative theories of linguistic relationship are discussed, and the major subgroups are presented.

In 1823, Julius von Klaproth identified the Tibeto-Burman phylum in Paris in his polyphyletic view of Asian linguistic stocks. Klaproth’s model of many distinct Asian linguistic phyla was initially controversial because many scholars in the West at the time entertained an undifferentiated view of Asian languages as all belonging to some nebulous all-encompassing language family. Klaproth’s Tibeto-Burman comprised Burmese, Tibetan, Chinese, and all the languages that could be demonstrated to be related to these three. He explicitly excluded languages today known to be Kradai or Daic (e.g., Thai, Lao, Shan); Austroasiatic (e.g., Mon, Vietnamese, Nicobarese, Khmer); and Altaic (e.g., Japanese, Korean, Mongolic, Turkic). The name Tibeto-Burman gained currency in English for the language family recognized by Klaproth and was widely used by scholars in the British Isles, e.g., Hodgson (1857), Cust (1878), Forbes (1878), Houghton (1896).

Some other scholars of the day followed the Indo-Chinese theory proposed by the Scots amateur John Casper Leyden, who died at the age of thirty-five after making a short but dazzling career in the British colonial administration in Asia during the Napoleonic wars. In 1807, Leyden proposed his

exuberant but poorly informed Indo-Chinese theory to George Barlow, governor general of India at Fort William, in which he claimed that all the languages in Asia and Oceania shared some “common mixed origin.”

This murky view appealed to adherents of Biblical mythology who were inclined to lump Chinese together with numerous other Asian languages into a grand Japhetic family, on the assumption that Chinese was one of the languages spoken by the descendants of Noah’s son Japheth, while some alternatively attempted to explain Chinese as an antediluvian language or as one of the “confounded” forms of speech with which Yahweh had afflicted mankind after the fall of the Tower of Babel. Klaproth was the first scholar to assign Chinese to its proper language family.

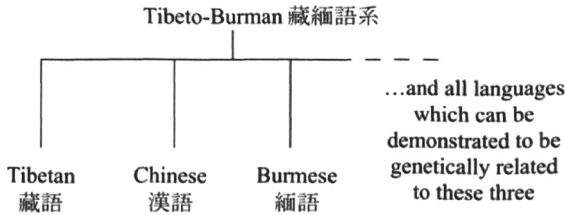

FIGURE 1: JULIUS VON KLAPROTH'S TIBETO-BURMAN FAMILY

The Biblically inspired Japhetic was not the only pan-Asian catchall. Wilhelm Schott wrote to the famous scholar of Himalayan languages Brian Houghton Hodgson to warn him against the “Turanian” theory then being propagated from Oxford. In 1856, Schott likewise published an essay warning against “Indo-Chinese.” Schott foresaw that scholars who used the label would continue to think in terms of the mistaken phylogenetic model that the label designated. Yet the Indo-Chinese model became the favorite of racist language typologists who believed that Asian languages were generally more rudimentary and that Asian peoples were more primitive than their Western counterparts.

Grammatical typology inspired language typologists such as Heymann Steinthal (1850, 1860), Ernest Renan (1858), Arthur de Gobineau (1854, 1855), and John Beames (1868) to rank Chinese and Thai together on the lowest rung of the evolutionary ladder of language development based on the languages’ “monosyllabicity” and lack of inflection. These scholars argued that Chinese and Thai must be closely related and that neither was part of Tibeto-Burman. James Byrne (1885) argued that “the causes which have determined the structure of language” lay in the varying “degrees of quickness of mental excitability possessed by different races of men.”

Chinese and Siamese ostensibly mediated a rudimentary, less evolved way of thinking and so were assigned to the lowest rungs of Steintal's ladder of language evolution.<sup>1</sup> The following quote typifies this once widespread genre of scholarly discourse.

La langue chinoise, avec sa structure inorganique et incomplète, n'est-elle pas l'image de la sècheresse d'esprit et de cœur qui caractérise la race chinoise? . . . Suffisante pour les besoins de la vie, pour la technique des arts manuels, pour une littérature légère de petit aloi, pour une philosophie qui n'est que l'expression souvent fine, mais jamais élevée, du bon sens pratique, la langue chinoise excluait toute philosophie, toute science, toute religion, dans le sens où nous entendons ces mots. (Renan 1858, 195–196).

Such reasoning contrasted starkly with the older but more sophisticated tradition of linguistic relativity, developed by John Locke (1690), Étienne de Condillac (1746), Pierre de Maupertuis (1748, 1756), and Wilhelm von Humboldt (1822, 1825, 1836). Linguists following this scholarly tradition, notably Julius von Klaproth (1823), Jean Jacques Nicolas Huot (Malte-Brun 1832, 1: 521), August Friedrich Pott (1856), and Friedrich Max Müller (1871, 1881), vehemently opposed the ideas of the racist language typologists, stressed that biological ancestry was independent of language, and argued that the relationship between language structure and human cognition was not at all so simplistic, but subtler, more interesting, and then, as today, still largely unexplored.<sup>2</sup>

---

1 Through the lens of historical hindsight, racist linguistic typology in the nineteenth century had its burlesque moments, as when some linguists contested Steintal's hierarchy on the basis of the argument that "Negeridiomen" could not possibly be positioned on rungs that were higher on the typological tree of language evolution than Chinese or Siamese, in view of the differences in the material cultures of the language communities concerned. Another ludicrous moment was the coinage of the term "analytic" to characterize languages such as English and French, which were no longer flamboyantly flexional and must therefore have ostensibly evolved beyond the stage of perfection purportedly reflected by Sanskrit.

2 The historical linguistic tradition of linguistic relativity was antagonistic to the racist tradition of the language typologists. Yet in the wake of the Second World War, the rejection of racism in most scholarly circles often went hand in hand with an unrefined, undifferentiated view of the distinct strands in the history of linguistic thought. Against this background, the backlash against the shortcomings in the writings Benjamin Lee Whorf, who died in 1941, led to the view, dogmatically propounded in many introductory courses in general linguistics worldwide, that all languages are created equal. This smug spirit of linguistic equivalence would have been music to the ears of Pierre Maine de Biran (1815), but fortunately scholars such as George Grace (1989) continued to contest this postwar orthodoxy.

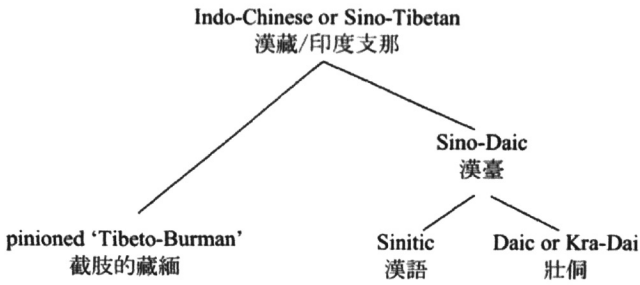

FIGURE 2: THE INDO-CHINESE OR SINO-TIBETAN THEORY:  
Kradai or Daic has been excluded since the Second World War.

At first, Indo-Chinese encompassed Asian languages from the Caspian Sea to Polynesia. This untenable construct embodied numerous misguided phylogenetic conjectures, so it came to be whittled down in successive stages. After Philipp von Siebold (1832) and Anton Boller (1857) presented their case for a distinct Altaic phylum, Ernst Kuhn (1883, 1889) attempted to remedy what was still wrong with the Indo-Chinese model by correcting the erroneous inclusion of Austroasiatic, but the resulting model still represented a false family tree. Yet some scholars and notable sinologists adopted the Indo-Chinese name and the false Indo-Chinese phylogeny, e.g., von der Gabelentz (1881), Forchhammer (1882), Conrady (1896), Laufer (1916), Wulff (1934).

In 1924, the French orientalist Jean Przyluski coined *sino-tibétain* as the French term for Indo-Chinese in the English and German sense.<sup>3</sup> This French term entered English in 1931 when Jean Przyluski and Gordon Luce coauthored an article on the root of the numeral one hundred in “Sino-Tibetan.” The new term did not catch on at once, but during the Great Depression in 1935, the American president Franklin Roosevelt instituted the employment scheme called the Works Progress Administration. Through WPA, the famous Berkeley anthropologist Alfred Kroeber, inspired by the enthusiasm of Robert Shafer, raised funding for his Sino-Tibetan Philology project. Changing the name of the model of linguistic relationship to the new Gallic label helped to deflect the widespread criticism against Indo-Chinese.

3 The need to coin a proper French term had actually become pressing, since in French *indochinois* referred politically and geographically to the French colonial dominions on the Indochinese peninsula and linguistically to the Mon-Khmer-Kolarian or Mon-Annam linguistic phylum, which Wilhelm Schmidt renamed “Austroasiatic” at the beginning of the twentieth century. Some British writers fond of terminological gallicisms also used the term “Indo-Chinese” in the meaning Austroasiatic, e.g., Sir Richard Temple (1903, 3: 251–284).

Shafer effectively ran the project for Kroeber but saw two things fundamentally wrong with “Sino-Tibetan.” In 1938, Shafer proposed to remove Kra-dai or Daic from the language family, but in the end he was not allowed to do so (Shafer 1955, 97–98). Shafer also put Sinitic on par with other divisions in the family. The two operations would have effectively heralded a return to Julius von Klaproth’s original Tibeto-Burman model. After Paul Benedict came to Berkeley in the winter of 1938–1939 to join the project, he traded in the name “Indo-Chinese” for “Sino-Tibetan.” Moreover, after the conclusion of the project in 1940, he took credit for removing Daic (1942). Benedict (1972) also restored Sino-Tibetan to its original Indo-Chinese shape, again isolating Chinese as the odd man out.

Ironically, after the Cultural Revolution, Chinese scholars adopted the Indo-Chinese model as it had been repackaged in America. Sino-Tibetan became 漢藏語系 *Hàn-Zàng yǔxì*, notwithstanding its empirically unsupported phylogeny and its racist legacy. Historically, Sino-Tibetan is rooted in the fact that morphosyntactic typology had perplexed less enlightened linguists of nineteenth century into believing that Chinese and Thai represented an inferior developmental stage on a Steinthal’s ladder of language evolution. This view relied on the assumption that Sinitic languages had never evolved and that Chinese had remained typologically unchanged, “without inflection, without agglutination” for millennia, e.g., Chalmers (1866).

By contrast, the informed historical linguistic view represented quite a different understanding of Chinese. Carl Richard Lepsius (1861, 492–496) proposed that Chinese tones had arisen from the merger of initials and the loss of finals based on correspondences between Chinese and Tibetan. He argued that entire syllables had been lost in Chinese and that Chinese ideograms once represented words that may often have contained more than just the root syllables whose reflexes survive in the modern pronunciations. The view of Chinese promulgated by Lepsius later inspired Bernhard Karlgren (1920, 1957) to conceive of Old Chinese as a “*langue flexionelle*” and to undertake the reconstruction of Old Chinese in accordance with the principles of the comparative method.

Two models of phylogenetic relationship sought to defy the Sino-Tibetan paradigm propagated from Berkeley, i.e., Sino-Himalayan (Bodman 1976, 1980) and Sino-Kiranti (Starostin 1994). Although neither proposal gained acceptance, these sallies made the crucial point that to date no evidence has ever been adduced in support of the Sino-Tibetan phylogenetic model, defined by its truncated “Tibeto-Burman” taxon encompassing all non-Sinitic languages. Methodologically, attempts to define all non-Sinitic

languages negatively in terms of Sinitic innovations that other languages lack or to invoke the argument of gross word order for Karen and Sinitic, as Benedict (1976) once did, are known to be phylogenetically meaningless. All comparative evidence amassed to date supports Julius von Klaproth's 1823 minimalist Tibeto-Burman tree, which epistemologically therefore continues to represent the default model.

However, the history of the field has left us with an unfortunate nomenclatural legacy. Whereas Tibeto-Burmanists in Klaproth's tradition used the name "Tibeto-Burman" for the family as a whole, Sino-Tibetanists have used the term "Tibeto-Burman" to denote all non-Sinitic languages as comprising a single taxon. In an attempt to escape this terminological morass, in 2004 the alternative name "Trans-Himalayan" was proposed for the linguistic phylum because the world's second most populous language family straddles the great Himalayan range along both its northern and southern flanks (van Driem 2007a, 226).

This neutral geographical term is analogous to "Indo-European" and "Afro-Asiatic" in reflecting the geographical distribution of the language family. The term "Afro-Asiatic" was coined in 1914 and replaced the earlier "Hamito-Semitic" for similar reasons. Hamitic was shown not to be a valid subgroup, just as "Sino-Tibetan," defined by its unitary non-Sinitic taxon, likewise denotes a false tree. The linguistic phylum is, of course, literally Trans-Himalayan in distribution. By far most of the roughly three hundred different Tibeto-Burman languages and three fourths of the major Trans-Himalayan subgroups are situated along the southern flanks of the Himalayas (Figure 3), while by far most speakers of Trans-Himalayan languages live to the north and east of the great Himalayan divide (Figure 4).

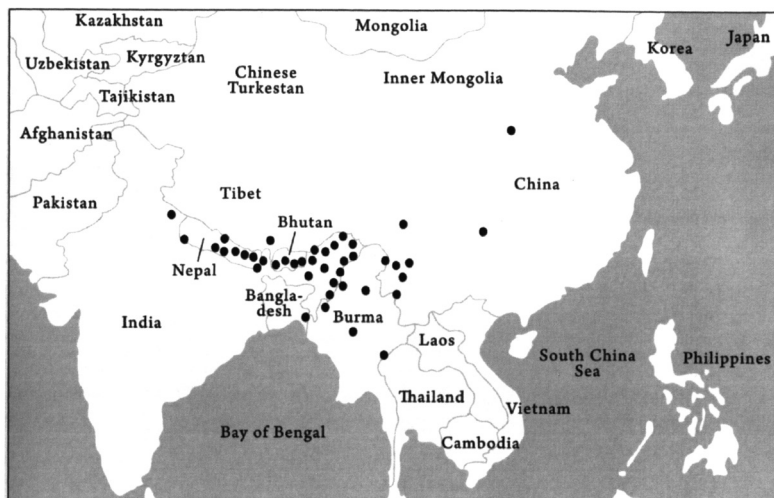

FIGURE 3: GEOGRAPHICAL DISTRIBUTION OF THE MAJOR TRANS-HIMALAYAN SUBGROUPS. Each dot represents not just one language but the putative historical geographical center of each of forty-two major linguistic subgroups.

### SPECULATIONS ON LINGUISTIC PHYLOGEOGRAPHY

Much more is known about the Tibeto-Burman language family today than in the days of Klapproth. Today we can identify forty-two subgroups for which there appears to be evidence and about which there is some degree of consensus. The 2012 version of the Fallen Leaves model, shown in Figure 5, contains a number of groups not mentioned when this model was first presented (van Driem 2001). The rGyalrongic subgroup was proposed and validated by Jackson Sun (2000a, 2000b). The Nàic subgroup, comprising Nàmùyì and Shìxīng and the closely related Nàish languages, i.e., Nàxī [nɑ̄hi˥], Na [nɑ̄], and Laze [lɑ̄tze˥], has been proposed by Jacques and Michaud (2011). Evidence for an Ęrsūish subgroup has been presented by Yu (2011). The validation of lower-order groups not only enables the validation of correctly delineated higher-order groups but will also give us a clear view of their internal phylogeny.





FIGURE 4: GEOGRAPHICAL DISTRIBUTION OF TRANS-HIMALAYAN LANGUAGES

Post and Blench (2011) presented evidence for Siangic, a group comprising Milang and Koro. At one level, Post and Blench envisage Siangic not as a Tibeto-Burman subgroup, but as an altogether non-Tibeto-Burman phylum that has left vestiges in Koro and Milang. A more conservative stance would be to treat Koro and Milang together as a Tibeto-Burman subgroup in their own right. In a similar vein, many scholars have recently publicly aired the view that Puroik, aka Sulung, normally deemed to be a member of the Kho-Bwa cluster of languages, is not a Tibeto-Burman language at all. Despite the apparently aberrant nature of some of the lexicon, Puroik, Koro, and Milang all exhibit a good share of Tibeto-Burman vocabulary. The history of Indo-European is instructive in this regard.

French shows a smidgen of Celtic lexicon that can be viewed as substrate, while the language itself is indisputably a Romance dialect. Words borrowed from the substrate language do not determine the linguistic affinity of a language. Until Ritter von Xylander (1835), Albanian was held to be a language isolate in Europe just like Basque. It is sobering to reflect that less is known today about Tibeto-Burman historical grammar than was known in 1835 about Indo-European historical grammar. The Gongduk language in Bhutan is analogous to Albanian, or for that matter much like Koro, Milang, and Puroik, in exhibiting much vocabulary that appears outlandish from a Tibeto-Burman perspective. Yet our perspective on Tibeto-Burman has been changing rapidly in recent years, as more becomes known about

the less well-documented languages of the phylum. Our understanding of what Starostin called “Tibeto-Burman in the narrow sense” is broadening to encompass a more informed and fine-mesh view.

The growing awareness in the field that the Tibeto-Burman analogues of Armenian, Hittite, and Albanian all appear to be found within the eastern Himalayas highlights the fact that the language family’s center of phylogenetic diversity lies squarely within the eastern Himalayas. The lexical diversity observed in many subgroups of the eastern Himalayas is just one residue of a complex and many-layered ethnolinguistic prehistory in a region of ancient human habitation.

The whereabouts and the names of the languages in the forty-two leaves that have fallen from the Trans-Himalayan tree are listed below. The most obvious disambiguations are indicated with the symbol ≠ and additional elucidation. Realities on the ground are far more complex than any short list can show. Related but entirely distinct and mutually unintelligible languages sometimes go by the same name, e.g., Magar, Limbu, Chinese. So the roughly 280 language labels in this nonexhaustive list obscure a great deal of dialectal and linguistic diversity.



**FIGURE 5: THE 2012 VERSION OF THE AGNOSTIC FALLEN LEAVES MODEL**

Thirty out of forty-two Tibeto-Burman subgroups lie south of the great Himalayan divide; seven to the north and east of the Himalayas; and five (Tshangla, Bodish, Nungish, Lolo-Burmese, and Kachinic), are distributed on both sides of the Himalayas

Sometimes the ethnic designation and the mother tongue do not match, as when a community considers itself Jīngpō but speaks the Lolo-Burmese language Zaiwa or when a community consider itself Tibetan but speaks a rGyalrongic language. Some languages are extinct (e.g., Pyu, Dura); believed to be extinct (e.g., the Sak languages); or moribund (e.g., Barām). In fact, most Tibeto-Burman languages are endangered with imminent extinction. A more detailed account can be found in the handbook *Languages of the Himalayas* and in the literature referenced therein.

**Angami-Pochuri** (southern Nagaland, northern Manipur, neighboring portions of Burma and Assam): Angami, Chokri a.k.a. Chakri, Kheza, Mao a.k.a. Sopvoma, Pochuri, Ntenyi, Maluri a.k.a. Meluri, Sema, Rengma, Kezhama, Senkadong.

**Ao** (central Nagaland and neighboring portions of Burma): Yacham, Ao Chungli, Ao Mongsen, Yimchungrü a.k.a. Yachumi, Sangtam a.k.a. Thukumi, Yacham and Tengsa, Lotha a.k.a. Lhota.

**Bái** (the area around Dàlǐ in Yúnnán province): Bái.

**Black Mountain Mönpa** (the Black Mountains of Bhutan): 'Olekha, Riti, Jangbi, 'Wangling.

**Bodish** (Tibet, Pakistan, India, Nepal, Sikkim, Bhutan): Balti, Purik, Ladakh, Zanskar, Lahul, Central Tibetan (dBus and Tsang), Sherpa, Ölmo Sherpa, Lhomi, Jirel, Kagate, Mustang, Limirong, Mugu, Northern Kham, Eastern Kham, Amdo Tibetan, Brokpa, Dzongkha, Lakha, Dränjoke, Choca-nga-ca-kha, Bumthang, Kheng, Mangde, Kurtöp, Chali, Dzala, Dakpa.

**Brahmaputran** a.k.a. Bodo-Koch and Northern Naga (West Bengal, Assam, Meghalaya, Arunachal Pradesh, northern Nagaland, and adjacent portions of Burma): Chutiya, Kokborok, Tiwa, Dimasa a.k.a. Hills Kachāḍī, Bodo, Plains Kachāḍī, Meche, Garo, Atong, Pani Koch, Ruga, Rabha, Tangsa, Nocte, Wancho, Kuwa, Haimi, Htangan, Konyak, Ponyo, Phom, Chang, Welam, Nokaw.

**Chepangic** (central Nepal): Chepang, Bhujeli.

**Dhimalish** (eastern Nepalese Terai, western Bhutanese duars): Dhimal, Toto.

**Digarish** a.k.a. “Northern Mishmi” (Dibang river valley, Lohit district, Arunachal Pradesh): Idu, Taraon a.k.a. Digaro.

**Dura** (central Nepal's Lamjung district): Dura.

**Ĕrsūish** (southern Sīchuān, northern Yúnnán): Ĕrsū, Tosu, Lizu.

**Gongduk** (south central Bhutan): Gongduk.

**rGyalrongic** (southern Sīchuān): Situ, Japhug, Tsobdun, Zbu, Lavrung (including Thurje Chenmo, and nDzorogs), Horpa (including rTau and Stod-sde).

**Hrusish** (western Arunachal Pradesh): Hruso a.k.a. Dhímmai a.k.a. Miji, Levai a.k.a. Bangru.

**Kachinic** a.k.a. Jinghpaw (northeastern India, northern Burma, southern Yúnnán): The various Kachin, Singpho, Jǐngpō or Jinghpaw languages and the Sak a.k.a. Luish languages Sak, Kadu, Andro, Sengmai, Chairel.

**Karbí** a.k.a. Mikir (Mikir Hills or Karbí Anglóng, neighboring districts of Assam): Karbí a.k.a. Mikir.

**Karenic** (lower Burma, the Tenasserim, and adjacent Thailand coastal regions): Pa’o, Pwo, Sgaw, Kayah, Brek a.k.a. Bwe, Bghai.

**Kho-Bwa** (western Arunachal Pradesh): Khowa a.k.a. Bugun, Sherdukpen, Puroik a.k.a. Sulung, Lishpa.

**Kiranti** (eastern Nepal): Pāñcthare Limbu, Phedāppe Limbu, Tamarkhole Limbu, Chathare Limbu, Yakkha, Chiling, Āṭhpahariyā (including Belhare), Lohorung, Yamphu, Mewahang, Kulung, Nachiring, Sampang, Sam, Chamling, Puma, Bantawa, Chintang, Dungmali, Thulung, Jero, Wambule, Tilung, Dumi, Khaling, Kohi, Bahing, Sunwar, Hayu.

**Kukish** a.k.a. Mizo-Kuki-Chin (Mizoram and Indo-Burmese borderlands): Mizo a.k.a. Lushai, Lai, Siyin, Thado, Tiddim Chin a.k.a. Paite a.k.a. Sokte a.k.a. Kamhau, Haka, Chinbok, Laizo, Lakher, Ashö, Khumi Chin, Hmar, Anal, Lakher a.k.a. Mara, Falam, Vaiphei, Lamgang, Simte.

**Lepcha** (Sikkim, Darjeeling, Kalimpong): Lepcha.

**Lhokpu** (southwestern Bhutan): Lhokpu a.k.a. Doya.

**Lolo-Burmese** (southwestern China, Burma, Southeast Asia): Burmese, Zaiwa (≠ Midžuish Zaiwa) a.k.a. Atsi, Lāshi, Māru (≠ Mru in the Chittagong), Maingtha a.k.a. Achang a.k.a. Ngachang, Hpon a.k.a. Hpun, Dānu, Taungyo a.k.a. Tāru (≠ Danaw), Phunoi, Akha, Lahu, Lisu, mBisu, Ahsi, and various Yí languages.

**Magaric** (central Nepal): Syāngjā Magar, Tanahū Magar, Pālpā Magar, Khām Magar a.k.a. Kham (≠ Tibetan Kham).

**Meithei** (Manipur): Meithei a.k.a. Manipuri

**Pyu** (extinct language of pre-Burmese epigraphy in Burma): Pyu.

**Midžuish** a.k.a. ‘Southern Mishmi’ (Lohit drainage, Lohit district, Arunachal Pradesh): Kaman a.k.a. Miju a.k.a. Mijhu, Zaiwa (spoken by the Meyöl clan near Walong ≠ Burmic Zaiwa).

**Mru** (in the Chittagong of Bangladesh): Mru a.k.a. Mǎru (≠ the Shan State Mǎru in Burma).

**Nàic** (southern Sìchuān, northern Yúnnán): Nàmùyì, Shìxíng, Nàxì, Na, Laze.

**Newaric** (central Nepal): Kathmandu Newar, Pahari Newar, Badikhel Newar, Chitlang Newar, Dolakha Newar, Barām, Thangmi.

**Nungish** (Yúnnán province, northern Burma): Trung, Ālóng, Rǎwang, Róuruò, Nung inc. Nūsū, and Ānù (≠ the Daic Nung in northern Vietnam).

**Qiāngic** (southern Sìchuān, northern Yúnnán): Southern Qiāngic, Northern Qiāngic, Mi-ñag (Mùyǎ), Prinmi (Pǔmì), Choyo (Quèyù), Tangut (Xìxià), Zhābā, Ěrgōng, Guìqióng.

**Raji-Raute** (western Nepal, Uttarakhand): Raji, Raute.

**Siangic** (Arunachal Pradesh): Koro, Milang.

**Sinitic** (China): Mandarin, Cantonese, Wú, Gàn, Xiāng, Hakka a.k.a. Kèjiā, Southern Mǐn (including Hokkien), Eastern Mǐn, Northern Mǐn, Central Mǐn.

**Tamangic** (central Nepal): Tamang, Gurung, Thakali, Chantyal, Ghale, Kaike, ’Narpa, Manangba.

**Tangkhul** (northeastern Manipur, neighboring parts of Burma): Tangkhul, Maring.

**Tani** a.k.a. Abor-Miri-Dafra (Arunachal Pradesh, neighboring portions of Assam): Apatani, Nyisu, Bengni, Nishing, Tagin, Yano, Sarak a.k.a. Hill Miri, Galo, Bokar, Ramo, Ashing, Pailibo a.k.a. Libo, Damu, Bori, Mishing a.k.a. Plains Miri, Padam, Shimong, Pasi, Panggi, Tangam, Karko, Minyong.

**Tshangla** a.k.a Shâchop (eastern Bhutan, enclaves in Arunachal Pradesh and Tibet): Tshangla a.k.a Shâchop or loconyms.

**Tÿjiã** (Húnán, Húběi and Guìzhōu provinces): Tÿjiã.

**West Himalayish** (Himachal Pradesh, Uttarakhand): Manchad, Tinan, Bunan a.k.a. Gari, Kanashi, Rangpo, Darma, Byangsi, Rangkas, Zhangzhung.

**Zeme** (southwestern Nagaland, northwestern Manipur, neighboring portions of Assam): Mzieme, Liangmai a.k.a. Kwoireng, Zeme a.k.a. Empeo Naga or Kacha Naga, Maram, Khoirao, Puiron, Rongmai a.k.a. Kabui or Nruanghmei.

Some of the subgroups in the above list of forty-two fallen leaves represent tentative subgrouping hypotheses that have yet to be subjected to closer scrutiny, e.g., Newaric, Qiāngic. By the same token, questions arise such as whether Bodish should include East Bodish, as well as Bodish proper, and how East Bodish should otherwise be renamed, or whether Brahmaputran should encompass both the Bodo-Koch, as well as the Northern Naga languages. In historical linguistics, it is preferable to work from the bottom up, i.e., starting with the tangible leaves that have fallen from the tips of the branches and then moving upward to gain an understanding of the nodes in the tree. Yet many Tibeto-Burman languages are still poorly documented and scantily described.

The Fallen Leaves model is no definitive phylogeny by definition. Though agnostic about higher-order subgrouping, the model does not deny that there is a family tree whose structure must be ascertained by historical linguistic methods. The continuing identification of subgroups presents a challenge to the current generation and to future generations of historical linguists in reconstructing the internal phylogeny of Tibeto-Burman on the basis of reliable data and regular sound laws and in not accepting without the support of historical comparative evidence false family trees that we inherit from our predecessors or find in the literature. Two of Shafer's old "divisions" continue to lead robust lives of their own as higher-order albeit vaguely delineated subgrouping proposals, i.e., Bodic and Burmic.

Recently, Jacques and Michaud (2011) have proposed a higher-order subgroup called Burmo-Qiāngic, comprising Lolo-Burmese and a subgroup newly christened Nà-Qiāngic. Nà-Qiāngic essentially represents the same catchall that used to be called "Qiāngic" *sensu lato*. This constellation of subgroups has now been rendered less nebulous, however, by Sun (2000a, 2000b), Yu (2011), and Jacques and Michaud (2011), who have validated the rGyalrongic, Ěrsūish, and Nàic subgroups respectively. In addition to

these three subgroups, Nà-Qiāngic also contains Mi-ñag (Mùyà), Prinmi (Pūmi), Choyo (Quèyù), Tangut (Xixià), Zhabā, Qiāngic *sensu stricto*, and perhaps Ērgōng and Guiqióng. The internal phylogeny of the latter medley of subgroups still has to be worked out, and the higher-order subgrouping hypotheses Nà-Qiāngic and Burmo-Qiāngic likewise require validation.

Another higher-order subgrouping hypothesis, Sino-Bodic, has a long history. Julius von Klaproth (1823) observed that Tibetan and Chinese appeared to be more closely related to each other than either was to Burmese. Simon (1927, 1928, 1929) and Forrest (1956, 1962) adduced lexical evidence that suggested a closer relationship between Chinese and Tibetan within the family. Although Shafer criticized Simon's work, Shafer (1955), too, observed that a closer genetic affinity obtained between Sinitic and Bodic than between any other two divisions. Later Bodman (1973, 1980), too, adduced evidence indicating a closer relationship between Sinitic and Bodic. The name 'Sino-Bodic' was proposed for the hypothesis, and additional lexical evidence for this affinity was adduced (van Driem 1997). Matisoff (2000) protested, but most of the Sino-Bodic evidence still stands (van Driem 2005). Possible new evidence for Sino-Bodic has been adduced by Nathan Hill (2011) and Zhèngzhāng Shàngfāng (2011). Future research will determine whether any of these supergroups will survive the test of time.

## THE UBIQUITOUS BUT NOT UNIVERSAL FATHER TONGUE CORRELATION

Despite valiant efforts by David Bradley (2012), Blench's (2009) claim still appears to hold that no rice agricultural terminology can be confidently reconstructed for the Tibeto-Burman phylum. Instead the linguistic ancestors of the Austroasiatics and the Hmong-Mien appear to be the likeliest candidates behind the early cultivation and later the domestication of Asian rice (van Driem 2011, 2012). Rather, as has long been widely presumed, the ancient Tibeto-Burmans probably cultivated foxtail millet *Setaria italica* and broomcorn millet *Panicum mileaceum*. Yet significant advances in linguistic palaeontology, supported by detailed descriptions and lexicographical documentation, in tandem with genetic work on these two cultigens may one day bring us closer to unraveling this portion of the Trans-Himalayan past.

A more obvious approach to tackling our prehistory than studying the link between languages and millet genes is the study of possible correlations between genetic markers in modern language communities and the phylogeography of the languages that they speak. However, from the beginning of the nineteenth century, when Jean-Baptist Lamarck

elaborated his theory of evolution, to the Second World War, interdisciplinary approaches tying linguistics and human biological ancestry have had a checkered history. Since genes are always inherited by offspring from their parents, while the languages spoken by people are not necessarily those that were spoken by their parents or grandparents, correlations between languages and genes could only be probabilistic at best, and there need not be any relationship whatsoever.

Therefore, it is highly interesting that when geneticists began to look for correlations between genetic markers and the geographical distribution of language communities, they began to find statistically relevant correlations, not with genetic markers on the maternally inherited mitochondrial DNA but with genetic markers on the paternally inherited Y chromosome. Such a tendency, first recognized in the pioneering studies of Poloni et al. (1997, 2000), has repeatedly been observed that some correlation obtains between the most frequent Y-chromosomal haplogroups of a community and the language the people happen to speak. This correlation between a community's language and that community's prevalent paternal ancestries is what I called the Father Tongue hypothesis (van Driem 2002).

There are a number of reasons why we might expect this outcome. Initial human colonization of any part of the planet must have involved both sexes in order for a population of progeny to establish itself. Once a population is in place, however, subsequent migrations could have been heavily gender biased. Subsequently, male intruders could impose their language while availing themselves of the womenfolk already in place. Theoretically, tribes of Amazons could have spread in a similar fashion. If so, then the telltale correspondences between mitochondrial lineages and the distribution of linguistic phyla would presumably have been detected by now, but any correlation between maternal lineages and linguistic phylogeography discerned to date has been underwhelming. The Father Tongue hypothesis suggests that linguistic dispersals were, at least in most parts of the world, posterior to initial human colonization and that many linguistic dispersals were predominantly later male-biased intrusions.

If we infer that a mother teaching her children their father's tongue has been a recurrent, ubiquitous, and prevalent pattern throughout linguistic history, then some of the mechanisms of language change over time are likely to be inherent to the dynamics of this pathway of transmission. Such correlations are observed worldwide. The correlation of Niger-Congo languages with Y-chromosomal haplogroups is a striking example (Wood et al. 2005). Likewise, the martial and male-biased historical spread of Hà



Chinese during the sinification of southern China, recounted in painstaking detail in the Chinese chronicles, is clearly reflected in the genetic evidence (Wen et al. 2004). A recent common ancestry between Native Americans and indigenous Altaians is also based preponderantly on the shared Y-chromosomal heritage and is not quite as well reflected in the mitochondrial lineages (Dulik et al. 2012).

While father tongues may predominate globally, mother tongues certainly do exist in the sense that there are areas on the planet where the linguistic affinity of a community corresponds more closely to the maternally transmitted mitochondrial lineage that the speakers share with other linguistically related communities. In this sense, in the north of today's Pakistan, the Balti speak a Tibetic mother tongue but profess a paternal religion that was first propagated in this area as early as the eighth century by men who came from the Near East, although the wholesale conversion of Baltistan to Islam is held to have begun only in the fourteenth century. The most prevalent mitochondrial DNA lineages amongst the Baltis are shared with other Tibetan communities, whereas the prevalent Y-chromosomal haplogroups probably entered Baltistan during the introduction of Islam (Zerjal et al. 1997, Quintana-Murci et al. 2001, Qamar et al. 2002).

At the same time, a jarring disconnect is sometimes seen between the occurrence of a highly salient genetic marker and the linguistic affinity of a community's language. Hungarians lack the TatC deletion defining the Y-chromosomal haplogroup N1c,<sup>4</sup> despite the sheer prevalence of this marker among all other Uralic language communities (Li et al. 1999). So, it deserves to be repeated that the linguistic ancestors of a language community were not necessarily the same people as the biological ancestors of that community. In fact, some of them could not have been the same people.

It also merits repeating that the time depth accessible to population geneticists studying polymorphisms on the genome is vastly greater than the reach of the linguistically reconstructible past. The wave of anatomically modern humans who introduced the protolanguages that were later to give rise to today's Asian linguistic phyla and language isolates can be dated to between 25,000 to 38,000 years ago (Rasmussen et al. 2011), and the antiquity of Y-chromosomal haplogroups such as O1 or O2 has been calculated to be greater than 10,000 years (Yan et al. 2011). Historical linguists, on the other hand, generally estimate the linguistically reconstructible past to be less than 10,000 years. This temporal gap must temper and inform all speculations regarding correlations between linguistic and genetic affinity.

With such caveats in place, how can we address the question formulated at the beginning of this section? On June 28, 2006, at a symposium held at l'École Française d'Extrême-Orient at Siem Reap, I identified the Y-chromosomal haplogroup O2a (M95) as the marker for the spread of Austroasiatic on the basis of the then-available genetic data (later published in van Driem 2007b). This view has been corroborated by subsequent genetic studies, e.g., Kumar et al. (2007), Chaubey et al. (2010). In the latter article, we concluded that Austroasiatic speakers in India today are derived from a dispersal from Southeast Asia, followed by extensive sex-specific admixture with local populations indigenous to the Subcontinent.

The autosomal data also reflect the distinction between two components in the genome, one represented by the predominantly indigenous maternal lineages and the other by the intrusive paternal O2a lineage that correlates with the linguistic affinity of the Austroasiatic language communities in the Indian subcontinent. These findings go well beyond Robert von Heine-Geldern's model of a Southeast Asian homeland and envisage a father-tongue spread of Austroasiatic, borne to the Indian subcontinent by predominantly male speakers from mainland Southeast Asia, but also involving a complex sociolinguistic prehistory of bidirectional gene flow across the Bay of Bengal (Chaubey et al. 2010). In many parts of the world, the mitochondrial DNA lineages often appear to reflect preponderantly older resident maternal lineages.

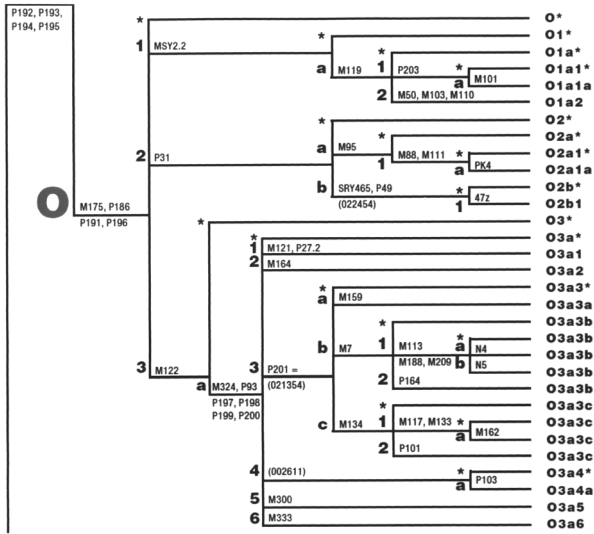

FIGURE 6: A PORTION OF THE Y-CHROMOSOME PHYLOGENETIC TREE RELEVANT TO THE FATHER TONGUE HYPOTHESIS WITH REGARD TO AUSTRONESIAN, AUSTROASIATIC, HMONG-MIEN, AND TRANS-HIMALAYAN AND THE PEOPLING OF EASTERN ASIA, REPRODUCED FROM KARAFET ET AL. (2008) WITH THE KIND PERMISSION OF THE COLD SPRING HARBOR LABORATORY PRESS.

The argument for the Father Tongue interpretation of the spread of major linguistic phyla in eastern Eurasia, such as Austroasiatic, is therefore not based solely on the frequencies of particular Y-chromosomal haplogroups. The Father Tongue hypothesis is originally based on the differential correlation of Y-chromosomal and mitochondrial lineages with the modern geographical distribution of language communities, i.e., the presence or absence of a strong correlation between linguistic affinity and genetic markers in the nonrecombinant portions of the genome. As one might expect, a distinct provenance for the maternal and paternal lineages appears to be reflected by studies of autosomal markers, as well (Chaubey et al. 2010). More important, a rooted topology of the Y-chromosomal tree in its entirety and of the Y-chromosomal haplogroup O in particular are central to the reconstruction of linguistic population prehistory in eastern Eurasia, operating on the assumption of the veracity of the Father Tongue hypothesis.

The available genetic data also enabled us to identify a correlation of the Y-chromosomal haplogroup O3a3b (M7) with the spread of Hmong-Mien, while our genetic samplings throughout the Himalayan region established

a correlation between Tibeto-Burman and the paternal lineage O3a3c (M134) (Parkin et al. 2006, 2007; Kraaijenbrink et al. 2007a, 2007b, 2009; van Driem 2011). The Y-chromosomal haplogroup O is becoming ever more minutely mapped, and most recently the phylogenetic positions of mutations P164 and PK4 within the haplogroup have been revised (Yan et al. 2011). Yet the antiquity calculated for many of these mutations is generally greater than the time depth that most historical linguists are willing to ascribe to the major language phyla.

Let us venture into the twilight beyond the linguistically reconstructible past to a time just after the Last Glacial Maximum, when the Y-chromosomal haplogroup O (M175) split up into the subclades O1 (M119), O2 (M268), and O3 (M122). Based on what is known about linguistic phylogeny and about the geographical distribution of modern linguistic communities today, the three subclades can putatively be assigned to three geographical loci along an east-west axis. For the sake of argument and schematic representation, and without any claim to geographical precision or veracity, I shall assign the haplogroup O1 (M119) to the drainage of the Pearl River and its tributaries in what today is the Chinese province of Guǎngdōng. I shall situate haplogroup O2 (M268) in southern Yúnnán and O3 (M122) to the area where today's northeastern India, southeastern Tibet, and northern Burma adjoin.

Since we have associated O2a (M95), which is a derivative clade of haplogroup O2 (M268), with the Austroasiatic language phylum, we might conjecture that Asian rice, perhaps both *japonica* and *indica* rice, was first domesticated roughly in the general area hypothetically imputed to O2 (M268) here. While the bearers of the O2a (M95) haplogroup became the *Stammväter* of the Austroasiatics, the other derivative paternal subclade O2b (M176) spread eastward, where it introduced rice agriculture to the areas south of the Yangtze. Though the bearers of the O2b (M176) haplogroup continued to sow seed as they continued to move ever further eastward, they left little or no linguistic traces, except maybe an Austroasiatic name for the Yangtze river, as proposed by Pulleyblank (1993), reflected as the toponym borrowed by Old Chinese as 江. \*kʰ roŋ (*jiāng*).

Meanwhile, back in southern Yúnnán, the early Austroasiatics initially spread from this locus to the Salween drainage in northeastern Burma and to the area that is today northern Thailand and western Laos. In time, the Austroasiatics would spread as far as the Mekong Delta, the Malay Peninsula, the Nicobars, and later even into eastern India, where they

would introduce both their languages and their paternal lineages to indigenous peoples of the Subcontinent.

At the locus putatively assigned to the haplogroup O<sub>3</sub> (M122), the bearers of this marker gave rise to the paternal lineages O<sub>3a3c</sub> (M134) and O<sub>3a3b</sub> (M7). While the bearers of the polymorphism O<sub>3a3c</sub> (M134) stayed behind in the area comprising northeastern India, southeastern Tibet, and northern Burma, the bearers of the O<sub>3a3b</sub> (M7) paternal lineage migrated eastward to settle in the areas south of the Yangtze. On their way, the early Hmong-Mien encountered the ancient Austroasiatics, from whom they adopted rice agriculture. The intimate interaction between ancient Austroasiatics and the early Hmong-Mien not only involved the sharing of knowledge about rice-agriculture technology, but also left a genetic trace in the high frequencies of haplogroup O<sub>2a</sub> (M95) in today's Hmong-Mien and of haplogroup O<sub>3a3b</sub> (M7) in today's Austroasiatic populations.

On the basis of these Y-chromosomal haplogroup frequencies, Cai et al. (2011, 8) observed that Austroasiatics and Hmong-Mien "are closely related genetically" and ventured to speculate about "a Mon-Khmer origin of Hmong-Mien populations." More precisely, the incidence of haplogroup O<sub>3a3b</sub> (M7) in Austroasiatic language communities of Southeast Asia appears to indicate a significant Hmong-Mien paternal contribution to the early Austroasiatic populations whose descendants settled in Southeast Asia, whereas the incidence of haplogroup O<sub>3a3b</sub> (M7) in Austroasiatic communities of the Indian subcontinent is undetectably low. The incidence of haplogroup O<sub>2a</sub> among the Hmong-Mien appears to indicate a slightly more modest Austroasiatic paternal contribution to Hmong-Mien populations than vice versa.

As the Hmong-Mien moved eastward, the bearers of haplogroup O<sub>2b</sub> (M176) likewise continued to move east. Even farther east, the O<sub>1</sub> (M119) paternal lineage gave rise to the O<sub>1a</sub> (M119) subclade, which moved from the Pearl River drainage eastward to the M<sub>n</sub> river drainage in the hill tracts of Fújiàn province and across the strait to Formosa, which consequently became the *Urheimat* of the Austronesians. Back west in the easternmost spurs of the Himalayas, the bearers of Y-chromosomal haplogroup O<sub>3a3c</sub> (M134) expanded eastward into Sichuan and Yúnnán, north and northwest across the Tibetan plateau, as well as westward into the Himalayas and southward into the Indo-Burmese borderlands. In the west and south, the early Tibeto-Burmans encountered Austroasiatics, who had preceded them.

Linguistic research on Trans-Himalayan languages can inform a chronologically layered view of ethnolinguistic prehistory. Not only do historical linguistics and genetics present two distinct and independent windows on the past. Even on a logarithmically distorted timescale, the time depth accessible to historical linguistics can be seen to be far shallower than the prehistorical depth accessible to human population genetics. The human population genetic data from beyond the linguistically reconstructible past embolden us to speculate that there must have been an early eastward and northward spread into East Asia, possibly including the linguistic ancestors of modern Tibeto-Burman language communities, who may have been the first bearers of the Y-chromosomal haplogroup O3a3c (M134). After this postglacial colonization, there must have been a number of discrete expansions in different directions at different times in the past.

To recapitulate the chronology of possible movements: (1) a postglacial northward wave of peopling at a time depth beyond what is generally held to be linguistically reconstructible by historical linguists, (2) a northeasterly spread of ancient Tibeto-Burmans to the putative early locus of Sino-Bodic, (3) incremental spread of diverse ancient Tibeto-Burman groups throughout the Himalayas, where there appears to be both linguistic and genetic evidence of pre-Tibeto-Burman populations, (4) a southward spread of Sino-Bodic, suggested by archaeology, genes, and language, bringing Sino-Bodic groups, including Sinitic, into contact with the ancient Hmong-Mien, the early Austroasiatics, the Austronesians, and a number of other Tibeto-Burman groups, (5) a Bodic spread across the Tibetan plateau spilling over into the Himalayas, as evinced by the distribution of Bodish, East Bodish, Tamangic, West Himalayish, and several other groups, and (6) the spread of Tibeto-Burman groups from Yúnnán into Southeast Asia, e.g., Karen, Pyu, and later Lolo-Burmese.

Following these tentatively reconstructed prehistoric stages of peopling, there were the historically attested ethnolinguistic dispersals: (7) the historically documented Hàn spread, clearly evinced in linguistics and genetics, probably assimilating non-Tibeto-Burman as well as other Tibeto-Burman groups, and (8) the historically documented spread of Bodish (i.e., Tibetic) across the Tibetan plateau.

The relative frequencies of the Y-chromosomal haplogroup O2a (M95) in various Tibeto-Burman populations of the Indian subcontinent (Sahoo et al. 2006, Reddy et al. 2007) suggest that a subset of the paternal ancestors of particular Tibeto-Burman populations in northeastern India, e.g., certain Bodo-Koch communities, may originally have been Austroasiatic

speakers who married into Tibeto-Burman communities or were linguistically assimilated by ancient Tibeto-Burmans. At the same time, median-joining network analyses of haplogroup O2a (M95) microsatellites have suggested a division in the Indian subcontinent between Tibeto-Burmans versus Austroasiatic and Dravidian-language communities. Austroasiatics and Dravidians show greater Y-chromosomal microsatellite diversification than Tibeto-Burman language communities, and the highest frequency of the O2a haplogroup is found in tribal populations in Orissa, Chattisgarh, and Jharkhand (Sengupta et al. 2006).

We must bear in mind that Y haplogroups are subject to selection and that frequencies change over time. As stressed above, haplotype frequencies by themselves are not a sufficient criterion. A rooted topology of the Y-chromosomal tree and its subsidiary clades provides key evidence. Moreover, the ethnolinguistic significance of paternal lineages becomes even more manifest when other portions of the genome are scoured for correlations with linguistic phylogeography. At the same time, our understanding of what constitutes neutral diversity has been tempered by mathematical modelling. Simulations have shown that a normally low-frequency allele could surf on a demic wave of advance and so attain high frequency across a vast area. Gene surfing during a spatial expansion is likely to result in distinct geographical sectors of low genetic diversity separated by sharp allele frequency gradients.

The result of recurrent bottleneck effects during range expansion into newly colonized territories can mimic complex phylogeographical patterns of adaptation and segregation into clades in postglacial niche refugia. Likewise, the massive introgression of resident genes into the incursive population can also be misinterpreted as the result of a selective process (Excoffier and Ray 2008, Excoffier et al. 2009). Surfing on the crest of a demic wave of expansion confers a selective advantage when compared to alleles left behind in the core area (Klopfstein et al. 2006, Moreau et al. 2011). Both the dynamics of sex-biased dispersals, as well as the process of the sexually asymmetrical introgression of resident alleles into incursive populations, can be modelled in terms of hybridization during range expansions (Petit and Excoffier 2009, Currat and Excoffier 2011).

An observed state of affairs for which a particular model of population prehistory has been advanced may in many cases very well be either the result of demography or of selection on genome diversity (Fagundes et al. 2007). However, we must keep in mind that a scenario that has been computed to be the statistically more likely scenario may not necessarily correspond to prehistorical reality.

Though presumably paternal lineages may often preferentially enjoy the benefits of surfing, incursive Y-chromosomal lineages can go entirely extinct, as the linguistic evidence<sup>4</sup> would suggest may very well have happened with the Y-chromosomal haplogroup N1c in Hungary.

We must also not lose sight of the fact that these speculations are based on correlations between language and Y-chromosomal haplogroups and that these, too, are interpreted in the light of the assumed veracity of the Father Tongue hypothesis over a vast stretch of time. This assumption may not hold true for all times in the past. Furthermore, correlations may be due to different kinds of circumstances other than causation or direct relationship. So while we are free to develop cautious arguments that buttress a speculative model of ethnolinguistic prehistory, such as the one outlined here, we must not lose sight of the essential distinction between the facts and our assumptions and inferences, as well as the precise nature and limitations of the empirical basis for our speculations.

Confronted with the overwhelming growing body of evidence in support of the Father Tongue hypothesis, Forster and Renfrew (2011, 1391) impute the spread of language families to “emigrating agriculturalists” who “took local wives.” This interpretation is a transparent attempt to succor Bellwood and Renfrew’s embattled First Farmers hypothesis, which seeks to ascribe the founding dispersals of language families to the spread of agriculture (Bellwood and Renfrew 2002). At the same time, in order to buttress Renfrew’s widely doubted hypothesis of an Indo-European homeland in Asia Minor, Forster and Renfrew also propose a correlation of Indo-European with the Y-chromosomal haplogroup J2a. In fact, it remains moot whether any part of Y-chromosomal phylogeography correlates well with the spread of the Neolithic horizon.

Not every population movement led to the spread of a language phylum, and population movements are not uniform in nature. Whether during the exodus of anatomically modern humans out of Africa or at the shallow time depth of the colonization of Oceania by Austronesian populations, the colonization of previously uninhabited lands invariably involved both sexes and the introduction of a language phylum. During the Neolithic horizon, the spread of farming was necessarily a sedentary and incremental process, which likewise must mostly have involved both sexes. Early farmers might have

---

<sup>4</sup> The presence of the Hungarian language in the region that was once Pannonia represents incontrovertible linguistic evidence of the advent of Uralic linguistic ancestors, a fact that is historically attested at any rate, but the hypothetical correlation of the Y-chromosomal haplogroup N1c with the Uralic linguistic phylum, of course, remains entirely conjectural.



been able to spread their language only at times of great surplus and concomitant population growth, perhaps sometimes involving the establishment of agricultural colonies elsewhere. By contrast, the modern ethnolinguistic composition of Asian populations must be understood, at least in part, as having resulted from male-biased linguistic intrusions, whether motivated by conquest, land grab, or the urge to seek out new habitats.

In my argument against the premises and the reasoning behind the hypothesis of the founding dispersals of language phyla having been mediated by the spread of farming, I proposed the telic and more complex Centripetal Migration theory (van Driem 2007b). I shall not repeat that exposition here, but with reference to Forster and Renfrew's willful interpretation of the Y-chromosomal haplogroup J2, I shall reiterate that, in the context of the Indian subcontinent, "the J2 haplogroup . . . appears to emanate from the Arabian Peninsula and, unlike haplogroups N and R1a, attains no high frequency in Ceylon" and "probably reflects the historically attested male-borne eastward spread of Islam," whereas Y-chromosomal haplogroups of the R subclades spread to the Subcontinent "from the northwest along with Indo-Aryan language across northern India and to Ceylon" (van Driem 2007b, 5). The spread of various Y-chromosomal R subclades is likely to be linked to the dispersal of Indo-European from an original homeland in the Pontic-Caspian steppe, while the current geographical distribution of the Y-chromosomal lineage L provides the likeliest candidate for a vestige of an earlier patrilingual dispersal of Elamo-Dravidian emanating from a region that encompassed the Bactria and Margiana of later prehistory.

## NOTES

- 1 Through the lens of historical hindsight, racist linguistic typology in the nineteenth century had its burlesque moments, as when some linguists contested Steinthal's hierarchy on the basis of the argument that "Negeridiomen" could not possibly be positioned on rungs that were higher on the typological tree of language evolution than Chinese or Siamese, in view of the differences in the material cultures of the language communities concerned. Another ludicrous moment was the coinage of the term "analytic" to characterize languages such as English and French, which were no longer flamboyantly flexional and must therefore have ostensibly evolved beyond the stage of perfection purportedly reflected by Sanskrit.
- 2 The historical linguistic tradition of linguistic relativity was antagonistic to the racist tradition of the language typologists. Yet in the wake of the Second World War, the rejection of racism in most scholarly circles often went hand in hand with an unrefined, undifferentiated view of the distinct strands in the history of linguistic thought. Against this background, the

backlash against the shortcomings in the writings Benjamin Lee Whorf, who died in 1941, led to the view, dogmatically propounded in many introductory courses in general linguistics worldwide, that all languages are created equal. This smug spirit of linguistic equivalence would have been music to the ears of Pierre Maine de Biran (1815), but fortunately scholars such as George Grace (1989) continued to contest this postwar orthodoxy.

- 3 The need to coin a proper French term had actually become pressing, since in French *indochinois* referred politically and geographically to the French colonial dominions on the Indochinese peninsula and linguistically to the Mon-Khmer-Kolarian or Mon-Annam linguistic phylum, which Wilhelm Schmidt renamed “Austroasiatic” at the beginning of the twentieth century. Some British writers fond of terminological gallicisms also used the term “Indo-Chinese” in the meaning Austroasiatic, e.g., Sir Richard Temple (1903, 3: 251–284).
- 4 The 2008 Y-Chromosome Consortium haplogroup labels are used here.
- 5 The presence of the Hungarian language in the region that was once Pannonia represents incontrovertible linguistic evidence of the advent of Uralic linguistic ancestors, a fact that is historically attested at any rate, but the hypothetical correlation of the Y-chromosomal haplogroup N1c with the Uralic linguistic phylum, of course, remains entirely conjectural.

## REFERENCES

- Beames, John. 1868. *Outlines of Indian Philology*. London: Trübner and Company.
- Bellwood, Peter, and Colin Renfrew, eds. 2002. *Examining the Farming/Language Dispersal Hypothesis*. Cambridge: McDonald Institute for Archaeological Research.
- Benedict, Paul King 1942. “Thai, Kadai, and Indonesia: A New Alignment in Southeastern Asia.” *American Anthropologist* 44: 576–601.
- . 1972. *Sino-Tibetan: A Conspectus*. Cambridge: Cambridge University Press.
- . 1976. “Sino-Tibetan: Another Look.” *Journal of the American Oriental Society* 96 (2): 167–197.
- Blench, Roger Marsh. 2009. “If Agriculture Cannot Be Reconstructed for Proto-Sino-Tibetan, What Are the Consequences?” Paper presented at the forty-second Conference on Sino-Tibetan Languages and Linguistics at Chiang Mai, November 3, 2009.
- Bodman, Nicholas Cleaveland. 1973. “Some Chinese Reflexes of Sino-Tibetan S-Clusters.” *Journal of Chinese Linguistics* 1 (3): 383–396.
- . 1980. “Proto-Chinese and Sino-Tibetan: Data Towards Establishing the Nature of the Relationship.” In *Contributions to Historical Linguistics: Issues and Materials*, edited by Frans van Coetsem and Linda R. Waugh, 34–199. Leiden: E. J. Brill.

- Boller, Anton. 1857. "Nachweis, dass das Japanische zum ural-altaischen Stamme gehört." *Sitzungsberichte der philosophisch-historischen Classe der kaiserlichen Akademie der Wissenschaften, Wien* 13: 393–481.
- Bradley, David. 2012. "Proto-Tibeto-Burman Grain Crops." *Rice* 4 (3–4): 134–141.
- Byrne, James. 1885. *General Principles of the Structure of Language*. 2 vols. London: Trübner and Company.
- Cai Xiaoyun, Zhendong Qin, Bo Wen, Shuhua Xu, Yi Wang, Yan Lu, Lanhai Wei, Chuanchao Wang, Shilin Li, Xingqiu Huang, Huí Li , and the Geographic Consortium. 2011. "Human Migration Through Bottlenecks from Southeast Asia into East Asia During Last Glacial Maximum Revealed by Y Chromosomes." *Public Library of Science* 6 (8): e24282.
- Chalmers, John. 1866. *The Origin of the Chinese: An Attempt to Trace the Connection of the Chinese with Western Nations in their Religion, Superstitions, Arts, Language and Traditions*. Hong Kong: De Souza & Co.
- Chaubey, Gyaneshwer, Mait Metspalu, Ying Choi, Reedik Mägi, Irene Gallego Romero, Siiri Rootsi, Pedro Soares, Mannis van Oven, Doron M. Behar, Siiri Rootsi, Georgi Hudjashov, Chandana Basu Mallick, Monika Karmin, Mari Nelis, Jüri Parik, Alla Goverdhana Reddy, Ene Metspalu, George van Driem, Yali Xue, Chris Tyler-Smith, Kumarasamy Thangaraj, Lalji Singh, Maito Remm, Martin B. Richards, Marta Mirazon Lahr, Manfred Kayser, Richard Villems, and Toomas Kivisild. 2010. "Population Genetic Structure in Indian Austroasiatic Speakers: The Role of Landscape Barriers and Sex-Specific Admixture." *Molecular Biology and Evolution*, doi: 10.1093/molbev/msq28.
- de Condillac, Étienne Bonnot. 1746. *Essai sur l'origine des connoissances humaines: Ouvrage où l'on réduit à un seul principe tout ce qui concerne l'Entendement Humain*. 2 vols. Amsterdam: Pierre Mortier.
- Conrady, August. 1896. *Eine indochinesische Causativ-Denominativ-Bildung und ihr Zusammenhang mit den Tonaccenten: Ein Beitrag zur vergleichenden Grammatik der indochinesischen Sprachen, insonderheit des Tibetischen, Barmanischen, Siamesischen und Chinesischen*. Leipzig: Otto Harrassowitz.
- Curat, Mathias, and Laurent Excoffier. 2011. "Strong Reproductive Isolation Between Humans and Neanderthals Inferred from Observed Patterns of Introgression." *Proceedings of the National Academy of Sciences* 108 (37): 15129–15134.
- Cust, Robert N. 1878. *A Sketch of the Modern Languages of East India*. London: Trübner and Company.
- van Driem, George. 2001. *Languages of the Himalayas: An Ethnolinguistic Handbook of the Greater Himalayan Region, Containing an Introduction to the Symbiotic Theory of Language*. 2 vols. Leiden: Brill.
- . 2002. "The Father Tongue Hypothesis: Sexually Dimorphic Dispersals in Prehistory." Paper presented at the seventeenth conference of the

- Indo-Pacific Prehistory Association, Academia Sinica, Taipei, September 9–15, 2002.
- . 2007a. “The Diversity of the Tibeto-Burman Language Family and the Linguistic Ancestry of Chinese.” *Bulletin of Chinese Linguistics* 1 (2): 211–270.
- . 2007b. “Austroasiatic Phylogeny and the Austroasiatic Homeland in Light of Recent Population Genetic Studies.” *Mon-Khmer Studies* 37: 1–14.
- . 2011. “Rice and the Austroasiatic and Hmong-Mien Homelands.” In *Dynamics of Human Diversity: The Case of Mainland Southeast Asia*, edited by Nick J. Enfield, 361–389. Canberra: Pacific Linguistics.
- . 2012. “The Ethnolinguistic Identity of the Domesticators of Asian Rice.” *Comptes Rendus Palevol* 11 (2): 117–132.
- Dulik, Matthew C., Sergey I. Zhadanov, Ludmila P. Osipova, Ayken Askapuli, Lydia Gau, Omer Gokcumen, Samara Rubinstein, and Theodore G. Schurr. 2012. “Mitochondrial DNA and Y Chromosome Variation Provides Evidence for a Recent Common Ancestry Between Native Americans and Indigenous Altaians.” *American Journal of Human Genetics* 90: 1–18.
- Excoffier, Laurent, Matthieu Foll, and Rémy J. Petit. 2009. “Genetic Consequences of Range Expansions.” *Annual Review of Ecology, Evolution and Systematics* 40: 481–501.
- Excoffier, Laurent, and Nicolas Ray. 2008. “Surfing During Population Expansions Promotes Genetic Revolutions and Structuration.” *Trends in Ecology and Evolution* 23 (7): 347–351.
- Fagundes, Nelson J. R., Nicolas Ray, Mark Beaumont, Samuel Neuenschwander, Francisco M. Salzano, Sandro L. Bonatto, and Laurent Excoffier. 2007. “Statistical Evaluation of Alternative Models of Human Evolution.” *Proceedings of the National Academy of Sciences* 104 (45): 17614–17619.
- Forbes, Charles James F. S. 1878. “On Tibeto-Burman Languages.” *Journal of the Royal Asiatic Society of Great Britain and Ireland* 10: 210–227.
- Forchhammer, Emile. 1882. “Indo-Chinese Languages.” *Indian Antiquary* 11: 177–189.
- Forrest, R. A. D. 1956. “Towards Common Tibeto-Burman.” *Wennti* 10: 1–18.
- . 1962. “The Linguistic Position of Róng (Lepcha).” *Journal of the American Oriental Society* 82 (3): 331–335.
- Forster, Peter, and Colin Renfrew. 2011. “Mother Tongue and Y Chromosomes.” *Science* 333: 13901–1391.
- von der Gabelentz, Hans Georg Conon. 1881. *Chinesische Grammatik mit Abschluss des niederen Stiles und der heutigen Umgangssprache*. Leipzig: T. O. Weigel.

- de Gobineau, Joseph Arthur. 1854–5. *Essai sur l'inégalité des races humaines*. 4 vols. Paris: Firmin-Didiot et Compagnie.
- Grace, George. 1989. *The Linguistic Construction of Reality*. London: Croom Helm.
- Hill, Nathan. 2011. "Multiple Origins of Tibetan O." *Language and Linguistics* 12 (3): 707–721.
- Hodgson, Brian Houghton. 1857. "Comparative Vocabulary of the Languages of the Broken Tribes of Népal." *Journal of the Asiatic Society of Bengal* 26: 317–371.
- Houghton, Bernard. 1896. "Outlines of Tibeto-Burman Linguistic Palæontology." *Journal of the Royal Asiatic Society* 1896: 23–55.
- von Humboldt, Wilhelm. 1822. "Über das vergleichende Sprachstudium in Beziehung auf die verschiedenen Epochen der Sprachentwicklung." In *Abhandlungen der Königlischen Preussischen Akademie der Wissenschaften, historisch-philosophische Klasse, aus den Jahren 1820 und 1821*: 239–260.
- . 1825. "Über das Entstehen der grammatischen Formen und ihren Einfluß auf die Ideenentwicklung." In *Abhandlungen der Königlischen Preussischen Akademie der Wissenschaften, historisch-philosophische Klasse, aus den Jahren 1822 und 1823*: 401–430
- . 1836. *Über die Verschiedenheit des menschlichen Sprachbaues und ihren Einfluß auf die geistige Entwicklung des Menschengeschlechts*. Berlin: Königlische Akademie der Wissenschaften.
- Jacques, Guillaume, and Alexis Michaud. 2011. "Approaching the Historical Phonology of Three Highly Eroded Sino-Tibetan Languages: Naxi, Na and Laze." *Diachronica* 28 (4): 468–499.
- Karlgren, Bernhard. 1920. "Le proto-chinois, langue flexionelle." *Journal Asiatique* 21 (15): 205–232.
- . 1957. *Grammata Serica Recensa (i.e. Bulletin of the Museum of Far Eastern Antiquities)* 29: 1–332.
- von Klaproth, Julius Heinrich. 1823. *Asia Polyglotta*. Paris: A. Schubart.
- Klopfstein, Seraina, Mathias Currat, and Laurent Excoffier. 2006. "The Fate of Mutations Surfing on the Wave of a Range Expansion." *Molecular Biology and Evolution* 23 (3): 482–490.
- Kraaijenbrink, Thirsa, Emma J. Parkin, Denise R. Carvalho-Silva, George van Driem, Guido Barbujani, Chris Tyler-Smith, Mark A. Jobling, and Peter de Knijff. 2009. "Genetic and Linguistic Borders in the Himalayan Region." In *Becoming Eloquent: Advances in the Emergence of Language, Human Cognition and Modern Cultures*, edited by Francesco d'Errico and Jean-Marie Hombert, 181–201. Amsterdam: John Benjamins.

- Kraaijenbrink, Thirsa, Karma Tshering of Gaselô, and Peter de Knijff. 2007. "Allele Frequency Distribution for 21 Autosomal STR Loci in Bhutan." *Forensic Science International* 170: 68–72.
- Kraaijenbrink, Thirsa, Jean Robert M. L. Opgenort, Nirmal Man Tuladhar, George van Driem, and Peter de Knijff. 2007. "Allele Frequency Distribution for 21 Autosomal STR Loci in Nepal." *Forensic Science International* 168 (2–3): 227–231.
- Kuhn, Ernst. 1883. *Über Herkunft und Sprache der transgangetischen Völker. Festrede zur Vorfeier des Allerhöchsten Geburts- und Namensfestes Seiner Majestät des Königs Ludwig II., gehalten in der öffentlichen Sitzung der Königlichen Akademie der Wissenschaften zu München am 25. Juli 1881.* Munich: Verlag der Königlichen Bayerischen Akademie.
- . 1889. "Beiträge zur Sprachenkunde Hinterindiens." *Sitzungsberichte der Königlichen Bayerischen Akademie der Wissenschaften (München), Philosophisch-philologische Classe* 2: 189–236.
- Kumar, Vikrant, Arimanda N. S. Reddy, Jagedeesh P. Babu, Tiprisetti N. Rao, Banrida T. Langstieh, Kumarasamy Thangaraj, Alla G. Reddy, Lalji Singh, and Battini M. Reddy. 2007. "Y-Chromosome Evidence Suggests a Common Paternal Heritage of Austro-Asiatic Populations." *BioMed Central Evolutionary Biology* 7: 47. <http://www.biomedcentral.com/1471-2148/7/47/>.
- Laufer, Berthold. 1916. "The Si-hia Language, a Study in Indo-Chinese Philology." *T'oung Pao* 17: 1–126.
- Lepsius, Carl Richard. 1861. "Über die Umschrift und Lautverhältnisse einiger hinterasiatischer Sprachen, namentlich der Chinesischen und der Tibetischen." *Abhandlungen der Königlichen Akademie der Wissenschaften zu Berlin aus dem Jahre 1860*, 449–496.
- Leyden, John Casper. 1808. "On the Languages and Literature of the Indo-Chinese Nations." *Asiatic Researches* 10: 158–289.
- Lì, J n, Peter A. Underhill, Vishal Doctor, Ronald W. Davis, Peidong Shen, L. Luca Cavalli-Sforza, and Peter J. Oefner. 1999. "Distribution of Haplotypes from a Chromosome 21 Region Distinguishes Multiple Prehistoric Human Migrations." *Proceedings of the National Academy of Sciences of the United States of America* 96: 3796–3800.
- Locke, John. 1690. *An Essay Concerning Humane Understanding, in Four Books.* London: Tho. Basset.
- Maine de Biran, François-Pierre-Gonthier. 1932. [1815]. "Note sur les réflexions de Maupertuis et de Turgot au sujet de l'origine des langues." In *Œuvres de Maine de Biran*, edited by Pierra Tisserand, 14 vols., 315–338. Paris: Librairie Félix Alcan.
- Malte-Brun, Conrad. 1832. *Précis de la géographie universelle, ou description de toutes les parties du monde sur un plan nouveau, d'après les grandes divisions naturelles*

- du globe: Nouvelle édition, revue, corrigée, mise dans un nouvel ordre et augmentée de toutes les nouvelles découvertes par J.J.N. Huot.* 6 vols. Brussels: Th. Lejeune.
- Matisoff, James Alan. 2000. "On 'Sino-Bodic' and Other Symptoms of Neosubgroupitis." *Bulletin of the School of Oriental and African Studies* 63 (3): 356–369.
- de Maupertuis, Pierre Louis Moreau. 1756a [originally 1748]. "Réflexions philosophiques sur l'origine des langues et la signification des mots." In *Œuvres*, nouvelle édition corrigée et augmentée 1: 258–309. Lyon: Jean-Marie Bruyset.
- . 1756b. "Dissertation sur les différents moyens dont les hommes se sont servis pour exprimer leurs idées." In *Œuvres*, nouvelle édition corrigée et augmentée 3: 435–468. Lyon: Jean-Marie Bruyset.
- Moreau, Claudia, Claude Bhérer, Hélène Vézina, Michèle Jomphe, Damian Labuda, and Laurent Excoffier. 2011. "Deep Human Genealogies Reveal a Selective Advantage to Being on an Expanding Wave Front." *Science* 334: 1148–1150.
- Müller, Friedrich Max. 1871. *Lectures on the Science of Language*. 2 vols. London: Longmans, Green and Company.
- . 1881. *Selected Essays on Language, Mythology and Religion*. 2 vols. London: Longmans, Green and Company.
- Parkin, Emma J., Thirsa Kraaijenbrink, Jean Robert M. L. Opgenort, Nirmal Man Tuladhar, George van Driem, Peter de Knijff, and Mark Jobling. 2007. "Diversity of 26 Y-STR Haplotypes in a Nepalese Population Sample: Isolation and Drift in the Himalayas." *Forensic Science International* 166 (2–3): 176–181.
- Parkin, Emma J., Thirsa Kraaijenbrink, Karma Tshering of Gaselô, Peter de Knijff, and Mark Jobling. 2006. "26-Locus Y-STR Typing in a Bhutanese Population Sample." *Forensic Science International* 161 (1): 1–7.
- Petit, Rémy J., and Laurent Excoffier. 2009. "Gene Flow and Species Delimitation." *Trends in Ecology and Evolution* 24 (7): 386–393.
- Poloni, Estella Simone, Ornella Semino, Giuseppe Passarino, A. S. Santachiara-Benerecetti, I. Dupanloup, André Langaney, and Laurent Excoffier. 1997. "Human Genetic Affinities for Y chromosome P49a,f/TaqI Haplotypes Show Strong Correspondence with Linguistics." *American Journal of Human Genetics* 61: 1015–1035 (cf. the erratum published in 1998 in the *American Journal of Human Genetics* 62: 1267).
- Poloni, Estella Simone, Nicolas Ray, Stefan Schneider, and André Langaney. 2000. "Languages and Genes: Modes of Transmission Observed Through the Analysis of Male-Specific and Female-Specific Genes." In *Proceedings: Evolution of Language, 3rd International Conference 3–6 April 2000*, edited by Jean-Louis Dessalles and Laleh Ghadakpour, 185–186. Paris: École Nationale Supérieure des Télécommunications.

- Post, Mark William, and Roger Marsh Blench. 2011. "Siangic: A New Language Phylum in North East India." Paper presented at the sixth International Conference of the North East Indian Linguistics Society, Tezpur University, January 31–February 2, 2011.
- Pott, August Friedrich. 1856. *Die Ungleichheit menschlicher Rassen hauptsächlich vom sprachwissenschaftlichen Standpunkte*. Lemgo und Detmold: Meyer'sche Hofbuchhandlung.
- Przyluski, Jean. 1924. "Le sino-tibétain" and "Les langues austroasiatiques." In *Les Langues du Monde*, edited by Antoine Meillet and Marcel Cohen, 361–384, 385–403. Paris: Librairie Ancienne Édouard Champion.
- Przyluski, Jean, and Gordon Hannington Luce. 1931. "The Number 'a Hundred' in Sino-Tibetan." *Bulletin of the School of Oriental Studies*, 6 (3): 667–668.
- Pulleyblank, Edwin George. 1983. "The Chinese and Their Neighbours in Prehistoric and Early Historic Times." In *The Origins of Chinese Civilization*, edited by David N Keightley, 411–466. Berkeley: University of California Press.
- Qamar, Raheel, Qasim Ayub, Aisha Mohyuddin, Agnar Helgason, Kehkashan Mazhar, Atika Manoor, Tatiana Zerjal, Chris Tyler-Smith, and S. Qasim Mehdi. 2002. "Y-Chromosomal Variation in Pakistan." *American Journal of Human Genetics* 70: 1107–1124.
- Quintana-Murci, Lluís, C. Krausz, Tatiana Zerjal, S. Hamid Sayar, Michael F. Hammer, S. Qasim Mehdi, Qasim Ayub, Raheel Qamar, Aisha Mohyuddin, U. Radhakrishna, Mark A. Jobling, Chris Tyler-Smith, and Ken McElreavey. 2001. "Y-Chromosome Lineages Trace Diffusion of People and Languages in Southwestern Asia." *American Journal of Human Genetics* 68: 537–542.
- Rasmussen, Morten, and Xiaosen Guo, Yong Wang, Kirk E. Lohmueller, Simon Rasmussen, Anders Albrechtsen, Line Skotte, Stinus Lindgreen, Mait Metspalu, Thibaut Jombart, Toomas Kivisild, Weiwei Zhai, Anders Eriksson, Andrea Manica, Ludovic Orlando, Francisco de la Vega, Silvano Tridico, Ene Metspalu, Kasper Nielsen, María C. Ávila-Arcos, J. Víctor Moreno-Mayar, Craig Muller, Joe Dortch, M. Thomas P. Gilbert, Ole Lund, Agata Wesolowska, Monika Karmin, Lucy A. Weinert, Bo Wang, Jun Li, Shuaishuai Tai, Fei Xiao, Tsunehiko Hanihara, George van Driem, Aashish R. Jha, François-Xavier Ricaut, Peter de Knijff, Andrea B. Migliano, Irene Gallego-Romero, Karsten Kristiansen, David Lambert, Søren Brunak, Peter Forster, Bernd Brinkmann, Olaf Nehlich, Michael Bunce, Michael Richards, Ramneek Gupta, Carlos Bustamante, Anders Krogh, Robert A. Foley, Marta Mirazón Lahr, François Balloux, Thomas Sicheritz-Pontén, Richard Villems, Rasmus Nielsen, Wang Jun, and Eske Willerslev. 2011. "An Aboriginal Australian Genome Reveals Separate Human Dispersals into Asia." *Science* 334 (6052): 94–98.



- Reddy, B. Mohan, B. T. Langstieh, Vikrant Kumar, T. Nagaraja, A. N. S. Reddy, M. Aruna, K. Thangaraj, A. G. Reddy, and Lalji Singh. 2007. "Austro-Asiatic Tribes of Northeast India Provide Hitherto Missing Genetic Link Between South and Southeast Asia." *Public Library of Science One* 2 (11): e1141. doi:10.1371/journal.pone.0001141
- Renan, Ernest. 1858. *De l'origine du langage*. Deuxième édition, revue et considérablement augmentée. Paris: Michel Lévy, Frères, Librairies-Éditeurs.
- Ritter von Xylander, Joseph. 1835. *Die Sprache der Albanesen oder Schkipetaren*. Frankfurt am Main: die Andreäische Buchhandlung.
- Sahoo, Sanghamitra, Anamika Singh, G. Himabindu, Jheeman Banerjee, T. Sitalaximi, Sonali Gaikwad, R. Trivedi, Phillip Endicott, Toomas Kivisild, Mait Metspalu, Richard Villems, and V. K. Kashyap. 2006. "Aprehistory of Indian Y chromosomes: Evaluating Demic Diffusion Scenarios." *Proceedings of the National Academy of Sciences of the United States of America* 103 (4): 843–848.
- Schott, Wilhelm. 1856. "Über die sogenannten indo-chinesischen Sprachen insonderheit das Siamische." *Abhandlungen der Königlichen Akademie der Wissenschaften zu Berlin aus dem Jahre 1856*, Philosophisch-historische Klasse: 161–179.
- Sengupta, Sanghamitra, Lev A. Zhivotovsky, Roy King, S. Q. Mehdi, Christopher A. Edmonds, Cheryl-Emiliane T. Chow, Alice A. Lin, Mitashree Mitra, Samir K. Sil, A. Ramesh, M. V. Usha Rani, Chitra M. Thakur, L. Luca Cavalli-Sforza, Partha P. Majumder, and Peter A. Underhill. 2006. "Polarity and Temporality of High-Resolution Y-Chromosome Distributions in India Identify Both Indigenous and Exogenous Expansions and Reveal Minor Genetic Influence of Central Asian Pastoralists." *The American Journal of Human Genetics* 78: 202–221.
- Shafer, Robert. 1955. "Classification of the Sino-Tibetan Languages." *Word, Journal of the Linguistic Circle of New York* 11: 94–111.
- . 1966. *Introduction to Sino-Tibetan, Part I*. Wiesbaden: Otto Harrassowitz.
- . 1967. *Introduction to Sino-Tibetan, Part II*. Wiesbaden: Otto Harrassowitz.
- . 1968. *Introduction to Sino-Tibetan, Part III*. Wiesbaden: Otto Harrassowitz.
- . 1974. *Introduction to Sino-Tibetan, Part IV*. Wiesbaden: Otto Harrassowitz.
- von Siebold, Philipp Franz Balthazar. 1832. "Verhandeling over de afkomst der Japanners." *Verhandelingen van het Bataviaasch Genootschap van Kunsten en Wetenschappen* 13: 183–275.

- Simon, Walter. 1927. "Zur Rekonstruktion der altchinesischen Endkonsonanten." *Mitteilungen des Seminars für Orientalische Sprachen an der Friedrich-Wilhelms-Universität zu Berlin* 30 (1): 147–167.
- . 1928. "Zur Rekonstruktion der altchinesischen Endkonsonanten, II. Teil." *Mitteilungen des Seminars für Orientalische Sprachen an der Friedrich-Wilhelms-Universität zu Berlin* 31(1): 157–204.
- . 1929. "Tibetisch-chinesische Wortgleichungen, ein Versuch." *Mitteilungen des Seminars für Orientalische Sprachen an der Friedrich-Wilhelms-Universität zu Berlin* 32 (1): 157–228.
- Starostin, Sergej Anatol'evič. 1994. "The Reconstruction of Proto-Kiranti." Paper presented at the twenty-seventh Congrès International sur les Langues et la Linguistique Sino-Tibétaines, Centre International d'Études Pédagogiques à Sèvres, October 14, 1994.
- Steinthal, Heymann. 1850. *Die Classification der Sprachen dargestellt als die Entwicklung der Sprachidee*. Berlin: Ferdinand Dümmler's Buchhandlung.
- . 1860. *Charakteristik der hauptsächlichsten Typen des Sprachbaues*. Berlin: Ferdinand Dümmler's Verlagsbuchhandlung.
- Sun, Jackson (= Sūn Tiānxīn). 2000a. "Parallelisms in the Verb Morphology of Sidaba rGyalrong and Lavrung in rGyalrongic." *Language and Linguistics* 1 (1): 161–190.
- . 2000b. "Stem Alternations in Puxi Verb Inflection: Toward Validating the rGyalrongic Subgroup in Qiangic." *Language and Linguistics* 1 (2): 211–232.
- Temple, Sir Richard C. 1903. *Census of India, 1901*, vol. 3: *The Andaman and Nicobar Islands: Report on the Census*. Calcutta: Office of the Superintendent of Government Printing, India.
- Wen Bo, Li Hui, Lu Daru, Song Xiufeng, Zhang Feng, He Yungang, Li Feng, Gao Yang, Mao Xianyun, Zhang Liang, Qian Ji, Tan Jingze, Jin Jianzhong, Huang Wei, Ranjan DeKa, Sù Bing, Ranajit Chakroborty, and Jin Lì. 2004. "Genetic Evidence Supports Demic Diffusion of Han Culture." *Nature* 431: 302–305.
- Wood, Elizabeth T., Daryn A. Stover, Christopher Ehret, Giovanni Destro-Bisol, Gabriella Spedini, Howard McLeiod, Leslie Louie, Mike Bamshad, Beverly I. Strassmann, Himla Soodyall, and Michael F. Hammer. 2005. "Contrasting Patterns of Y Chromosome and mtDNA Variation in Africa: Evidence for Sex-Biased Demographic Processes." *European Journal of Human Genetics* 13: 867–876.
- Wulff, Kurt. 1934. *Chinesisch und Tai: Sprachvergleichende Untersuchungen*. Copenhagen: Levin & Munksgaard.
- Yan Si, Chuan-Chao Wang, Huí Lì, Shi-Lin Li, Jin Li, and the Genographic Consortium. 2011. "An Updated Tree of Y-Chromosome Haplogroup O

- and Revised Phylogenetic Positions of Mutations P164 and PK4.” *European Journal of Human Genetics* 19: 1013–1015.
- Yu, Dominic. 2011. “Reconstructing Proto-Ersuic.” Paper presented at the seventeenth Himalayan Languages Symposium, Kōbe City University of Foreign Studies, September 6, 2011.
- Zerjal, Tatjana, B. Dashnyam, A. Pandya, Manfred Kayser, Lutz Roewer, F. R. Santos, W. Schiefenhovel, N. Fretwell, M. A. Jobling, S. Harihara, K. Shimuzu, D. Semjidmaa, Antti Sajantila, P. Salo, M. H. Crawford, E. K. Ginter, Oleg V. Efgrafov, and Chris Tyler-Smith. 1997. “Genetic Relationships of Asian and Northern Europeans, Revealed by Y Chromosomal DNA Analysis.” *American Journal of Human Genetics* 62: 1174–1183.
- Zhèngzhāng, Shàngfāng. 2011. “On Tibeto-Chinese Correspondence of Fifty Body Part Terms.” *Mínzú Yǔwén* 2011 (4): 16–18.

## BIOGRAPHY

George van Driem directs the Linguistics Institute at the University of Bern, where he occupies the chair of historical linguistics. He has written several grammars of languages of the Himalayas (Limbu, Dumi, Dzongkha, and Bumthang) and authored a two-volume ethnolinguistic handbook entitled *Languages of the Himalayas* (2001, Brill). In Bhutan, he discovered two languages previously unknown to science (Black Mountain Mönpa and Gongduk), and he collaborates with linguists and population geneticists to reconstruct human population prehistory in the Old World. His PhD students and postdoc scholars have conducted pioneering work in the Asian heartland.